



3170 Wasson Road • Cincinnati, OH 45209 USA
Phone 513-533-7340 • Fax 513-533-7343
E-Mail: marwin@richardsind.com • www.marwinvalve.com

I&M 10000 Series

Installation & Maintenance Instructions for Marwin 10000 Series Three Piece Ball Valves

Warning: Marwin Valve ball valves must only be used, installed, and repaired in accordance with these Installation & Maintenance Instructions. Observe all applicable public and company codes and regulations. In the event of leakage or other malfunction, call a qualified service person; continued operation may cause system failure or a general hazard.

Please read these instructions carefully!

Your Marwin Valve product will provide you with long, trouble-free service if it is correctly installed and maintained. Spending a few minutes now reading these instructions can save hours of trouble and downtime later. When making repairs, use only genuine Marwin Valve parts, available for immediate shipment from the factory.

Scope

This manual is intended as a guide to assist customers in the storage, installation, and maintenance of Marwin 10000 Series Ball Valves. Subsequent additions or special instructions will be provided for special ball valves, critical service, or customer requirements.

Applicability

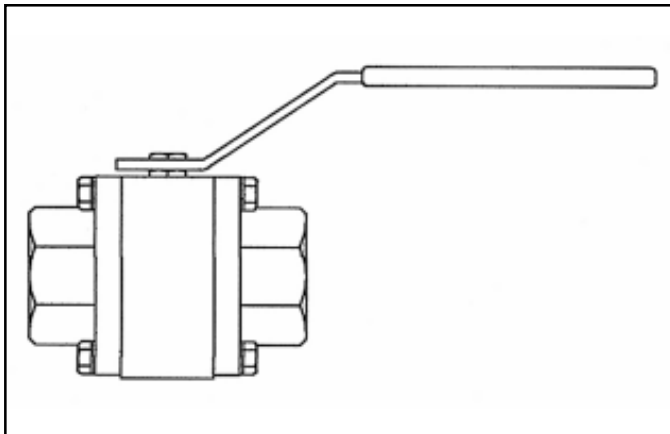

1. This manual is applicable to the 10000 Series Marwin three piece ball valves.

Caution

To help prevent injury to personnel or damage to equipment,

please read this section completely before performing any operations.

1. Valve pressure ratings are based on many variables, including valve series and size, as well as body, seat and bolt material. Verify that application does not exceed the pressure or temperature rating on the nameplate.
2. **ALWAYS** depressurize the line with the valve in the **OPEN** position before disassembly. Cycle valve in depressurized line before loosening bolts.
3. Wear protective equipment and take appropriate precautions to safeguard against injury caused by the discharge of trapped fluids.
4. Use only Marwin recommended spare parts for maintenance.
5. To ensure safety and maintain warranty, never modify valve in any way without prior approval from Marwin.

Storage

A petroleum-based oil (silicone free) is used as lubrication on all internal surfaces. This may be removed with a solvent if found objectionable. All valves are adequately packed in a strong cardboard case in such a way as to avoid any possible damage during transport and storage.

CAUTION: If ball valves are not destined for immediate use, the following precautions should be taken:

1. If possible, leave the ball valves in their packing cases during the period of storage.
2. Ball valves must remain in open position during this time.
3. In order to prevent damage, protective plastic covers on valve ends should not be removed until immediately prior to installation.
4. It is advisable to store the valves in waterproof conditions. Ball valves should be protected to safeguard against humidity, moisture, dust, dirt, sand, mud, salt spray, and seawater.
5. All valves complete with actuators are to be stored in dry conditions.
6. Valves to be stored for a long period of time should be checked by the quality control personnel every six months; every three months when valves are automated.

Maintenance During Storage Period

- Internal surface should be inspected to check for dust or other foreign objects.
- Rust or dust must be removed by cleaning with proper solvent.
- After cleaning, ball valves must be lubricated with an adequate lubricant.
- Ball valves should be operated for at least two complete cycles before installing or returning to storage.

Installation

The ball valves may be installed in any position using Standard Pipe Fitting Practice.

CAUTION: Before installation of the valve:

1. Pipe must be free of tension both during and after installation.
2. Pipe must be flushed to clean dirt, welding residues, etc. which would damage ball or seats.
3. The valve should be kept in OPEN POSITION during installation and protective plastic covers must be removed only at the moment of installation.
4. Before shipment, the ball is lubricated with a pure Vaseline oil. This can be easily removed with an application compatible solvent if required.
5. If the valve was specified to be tested per ASTM 16.34, there may be some trapped water between the ball and the body cavity. This can be removed by partially opening the valve, thereby exposing the cavity to the through port of the ball.
6. Special care should always be taken when installing automated ball valves that the ball is in the proper position.

■ **Installation of Threaded Ends**

1. Unless otherwise specified, pipe threads are American National Standard Taper Pipe Threads (NPT) per ANSI B1.20.1, and require that a pipe sealant be used.
2. Use an anti-seize thread sealant to seal and prevent galling.
 - a. Marwin recommends PTFE-based liquid sealant or Grafoil tape as thread sealants.
 - b. Notes:
 1. Use all pipe sealant products in accordance with the manufacturer's instructions and good piping practices.
 2. Correct lubrication of stainless steel pipe threads is especially important to prevent galling.
3. To prevent distortion or damage to the valve, do not apply torque through the valve. When tightening valve, use wrench on the end nearest the pipe being tightened.
4. Always leak test the system before using.

■ **Installation of Welded-End Ball Valves**

1. Tack weld in four points on both end caps.
2. Lift out the valve body and seat per disassembly section in this procedure and complete the welding.
3. Allow welds to cool.

4. Reassemble valve per section in this procedure and inspect for easy operation.
5. Extended end valves may be welded into place without disassembly using the following guidelines:
 - a. Valve must be in the full open position.
 - b. Limit continuous weld time to one minute.
 - c. Direct moving air across finned area or wrap extended end with wet cloth.
 - d. Check body bolts for proper torque after welds have completely cooled per **Assembly Section** of this procedure.

Note: Guide for extended valve installation does not apply to UHMW-PE or Delrin seats or standard EPDM or Nitrile body seals due to the low tolerance to high temperatures of these materials.

■ **Installation of Flanged Ends**

1. Verify valve is in the full open position.
2. Use the appropriate size bolt and heavy hex nut (not included) as recommended for flange size and class.
3. Flange connection requires gasket (not included).
4. Follow gasket manufacturer's recommended practice for tightening flange bolts.

Manual Operation

1. Open and close the valve by turning the handle one-quarter turn (90°).
2. Valve is in open position when handle is in line with the pipe.
3. Valve is in closed position when the handle is perpendicular to the pipe.

Maintenance

Before starting maintenance, please read information contained in the **Caution Section** of the manual.

1. Open and close the ball valve at least once to release the pressure completely from valve body.
2. Ball valves, if correctly used, normally do not need any internal lubrication and maintenance. However, when necessary, ball or seats can be replaced by qualified personnel following the instructions of this manual.
3. For further information, please refer to **SPARE PARTS LIST Section**.

Valve Disassembly

A. To inspect and/or Replace Body Seals, Seats, Packing & Ball

Reference cross section for part identification.

1. Valve must be in the open position.
2. Remove valve from line.
3. Remove bolts (11) securing end cap and separate end cap (2) from body (1).

4. Close the valves and remove ball (3), seats (7) and body seal (15). Be careful not to damage the ball.
5. Remove the handle nut (13), handle (12), stem nut (14), gland (5) thrust washer (8), and packing (9).
6. Push the stem (4) into the body (1). Remove thrust washer (8) from stem.

B. Inspection and Replacement

With the valve completely disassembled, clean and examine all components:

1. The surface of the ball should be free from any defect. If any are found, the ball should be replaced. Using a defective ball will be extremely detrimental to valve performance.
2. Seats. Replacement of seats is recommended.
3. Stem seals and body seals. Should be discarded and replaced.
4. Remaining components of the valves. After cleaning, carefully examine for wear, corrosion, and mechanical damage. Replace all defective parts.
5. Clean inside of body and stem housing. Light grease, compatible with line fluid, can be used on ball, seals and stem surfaces.

NOTE: A spare parts list is available for this valve. Please refer to explosion view below for identification. Please specify specific valve number to ensure proper parts are ordered. Marwin Valve does not take responsibility for incorrectly ordered spare parts.

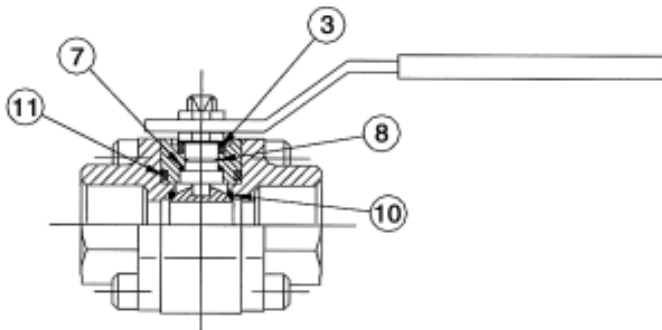

Spare Parts Kit		
Item #	Quantity	Part Name
7	2	Seats
8	2	Thrust Washer
9	1	Packing
15	2	Body Seal
18	1	O-Ring

BODY BOLT TORQUE VALUE TABLE (ft/lbs)

Series/Size	Bolt Information		Bolting Material		
	Bolt Size	Bolt Quantity	BD Steel	B7M NACE	B8 St STL
10,000 Series					
1/4" - 1/2"F	0.375	6	25	21	14
3/4"F	0.5	6	54	42	35
1"F	0.562	6	67	58	54
1-1/4"-1-1/2"F	0.562	8	67	58	54
2"F	0.562	10	67	58	54

Re-Assembly

A. Stem

1. Replace thrust washer (8) and O-Ring (18) then insert the stem from inside of body.
2. Install stem packing (9), thrust washer (8), gland (5), spring washers (6), stop plate (16) and stem nut (10) and tighten until snug, then one-half turn. To avoid rotation of stem, insert the handle and ball.
3. Install handle (12) and handle nut (13) then tighten.

B. Ball, Seats and Seals

1. Install seat (7) in body (1).
2. Place the stem (4) in closed position and insert the ball (3), aligning groove in ball with bottom of stem.
3. Position the ball in the open position, then insert the seat (7), body seal (15), and end cap (2).
4. Hand tighten all bolts (11).
5. Tighten nuts to recommended values using an alternating/opposing pattern with no more than 1/4 turn on each nut before alternating.

Testing

1. After completing the reassembly, check that valve operates smoothly by opening and closing valve several times.
2. If entire valve was removed from line and if facilities are available, test the ball valve to appropriate specifications.

Troubleshooting

A. Stem Leakage

1. Leakage in the stem packing area may be eliminated by increasing the torque on the stem nut (14) in one-quarter turn increments. If leakage persists, replace stem packing (9).

B. Body Seal Leakage

1. Check the torque of the body bolts (11) according to Torque

Exploded View

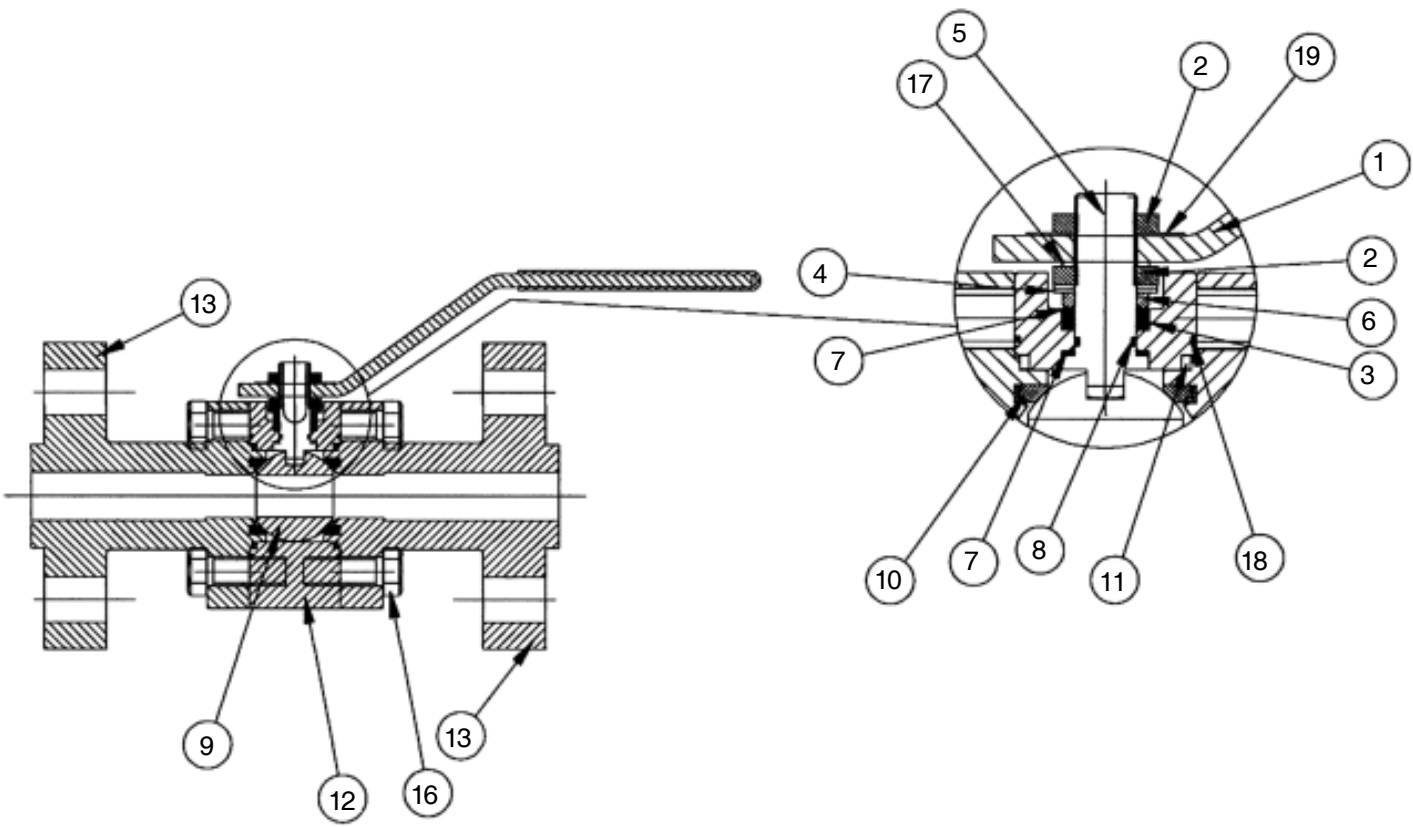

10000 Series					
Item	Quantity	Part Name	Item	Quantity	Part Name
1	1	Handle	10	2	Seats
2	2	Nut	11	2	First Body Seal
3	1	Packing Rings	12	1	Body
4	2	Spring Washers	13	2	End Caps
5	1	Stem	16	12	Bolts
6	1	Gland	17	1	Stop Washers
7	2	Thrust Washer	18	2	Second Body Seal
8	1	"O" Ring Stem	19	1	Name Plate
9	1	Ball			



3170 Wasson Road • Cincinnati, OH 45209 USA
 Phone 513-533-7340 • Fax 513-533-7343
 Phone Toll-Free: 800-628-2583 (USA)
 E-Mail: marwin@richardsind.com
www.marwinvalve.com