

Mark 5800HP

High Back Pressure Regulator

The Mark 5800HP is a high pressure, back pressure regulator designed to maintain upstream pressure of gases and liquids. As a compact, lightweight product, it is well suited for applications where space and weight are at a premium.

With a robust, piston design, the MK5800HP can handle setpoints up to 2500 psig (172 bar) at 450°F (232°C) with ease and the large flow capacity for a valve of this style is among the highest in the industry. The T-bar adjusting handle allows for a lighter spring and more sensitive regulator than those models with a fixed knob. This added sensitivity contributes greatly to the accuracy of the valve.

The valve is normally closed, with the soft seat maintaining ANSI Class VI shutoff. When the inlet rises above the spring setpoint, the pressure forces the piston upwards to open and relieve the pressure. As the inlet pressure falls to the spring setpoint level, the valve then throttles closed to ensure the pressure doesn't drop below the spring setpoint.

Among other applications, the MK5800HP can be used for:

- high pressure vessel venting
- high pressure injection applications
- gas/liquid sampling stations
- compressor skids
- test stands



FEATURES

- Complete barstock construction — ensures body/trim material quality and facilitates usage of alloy materials
- High Flow — Cv 1.0 (0,86 Kv) in a compact design
- Full pressure rating across entire temperature range — maximum setpoints available at maximum pressures
- T-Bar handle — permits usage of lighter, more sensitive spring
- Proof-tested to 12,000 psi (827 bar) — nearly five times pressure rating, ensures safety when working with high pressures
- A variety of seal materials ensure compatibility with medium setpoint



Jordan Valve

Jordan Valve, a Division of Richards Industries

3170 Wasson Road • Cincinnati, Ohio 45209

Telephone 513-533-5600 • Fax 513-871-0105

Toll-Free Telephone: 800-543-7311 (U. S. A. & Canada)

E-Mail: info@richardsind.com • URL: www.jordanvalve.com

SPECIFICATIONS

Line Size: 1/2", 3/4", 1" (DN15, DN20, DN25)

End Connections

- Threaded
- Socket Weld
- Flanged (welded)

Standard Materials

- Body/Spring Housing: 316L Stainless Steel
- Adjusting Screw: Nitronic 60
- Seat: Teflon — standard; Nylon, PEEK & Delrin optional
- Orifice: 316L Stainless Steel
- Piston: Nitronic 60
- Cylinder: 316L Stainless Steel
- O-Rings: Buna-N (-65°F to 250°F/-54°C to 121°C); EPDM (-20°F to 450°F/-29°C to 232°C); Viton (-15°F to 400°F/-26°C to 204°C)
- Trim Bushings & Seals: Teflon
- Shutoff: Class VI
- For other body/trim materials, please contact factory

Body Pressure/Temperature

- 2500 psig @ 100°F (172 bar @ 38°C)
- 2500 psig @ 450°F (172 bar @ 232°C)

Standard Cv: 1.0 (0,86 Kv)

Standard Range: 400 - 2500 psi (58 - 172 bar); For lower setpoints, contact factory

DIMENSIONS

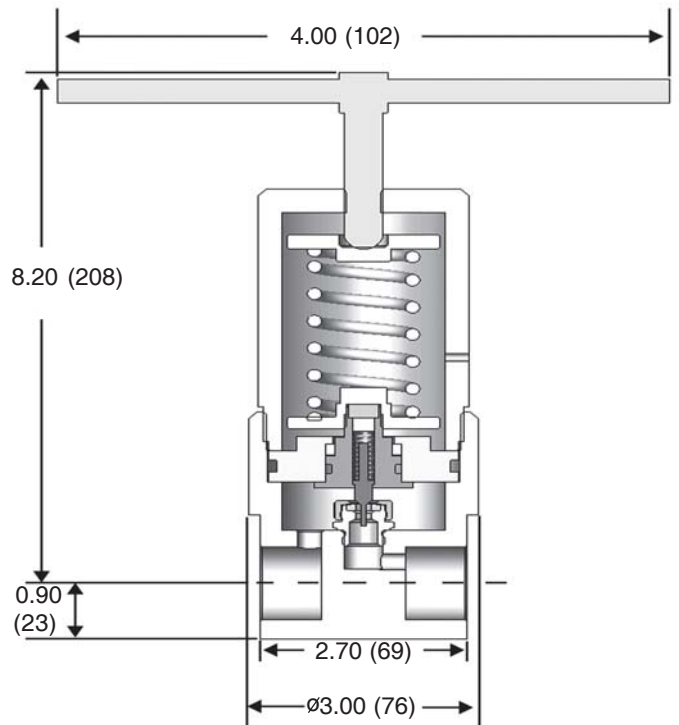

ORDERING SCHEMATIC

1		Model	
	5800HP		Standard

2		Body Material	
	316		316

3		O-Ring	
	B		Buna
	E		EPDM
	V		Viton

4		Body			
		Size	End Connection		
	A	1/2" (DN15)	A	FNPT	
	B	3/4" (DN20)	B	FSW	
	C	1" (DN25)	C	150# Flange	
			D	300# Flange	
			E	600# Flange	
			F	900# Flange	
			G	1500# Flange	
	ZZ		Non-Standard		

5		Trim	
	EE		Cv 1.0 316/TFE
	ZZ		Non-standard

6		Set Range	
	R9		400-2500 psi (58 - 172 bar)
	ZZ		Non-standard

7		Accessory	
	SC		Clean F/Oil Free
	ZZ		Non-standard