



JORDAN VALVE

3170 Wasson Road • Cincinnati, OH 45209 USA
Phone 513-533-5600 • Fax 513-871-0105
E-Mail: info@richardsind.com • www.jordanvalve.com

I & M 55 - 65

Installation & Maintenance Instructions for Mark 55 and Mark 65 Vacuum Regulators

Warning: Jordan Valve Pressure Regulators must only be used, installed, and repaired in accordance with these Installation & Maintenance Instructions. Observe all applicable public and company codes and regulations. In the event of leakage or other malfunction, call a qualified service person; continued operation may cause system failure or a general hazard. Before servicing any valve, disconnect, shut off, or bypass all pressurized fluid. Before disassembling a valve, be sure to release all spring tension.

Please Note

The Mark 55 and Mark 65 Vacuum Regulators have the same body and seating construction as the Mark 50 and the Mark 60 respectively. Only the Spring Assembly and the guiding is different. This supplement presents only those instructions necessary to maintain the topworks. Refer to the MK 50 or MK60 I & M for other maintenance procedures.

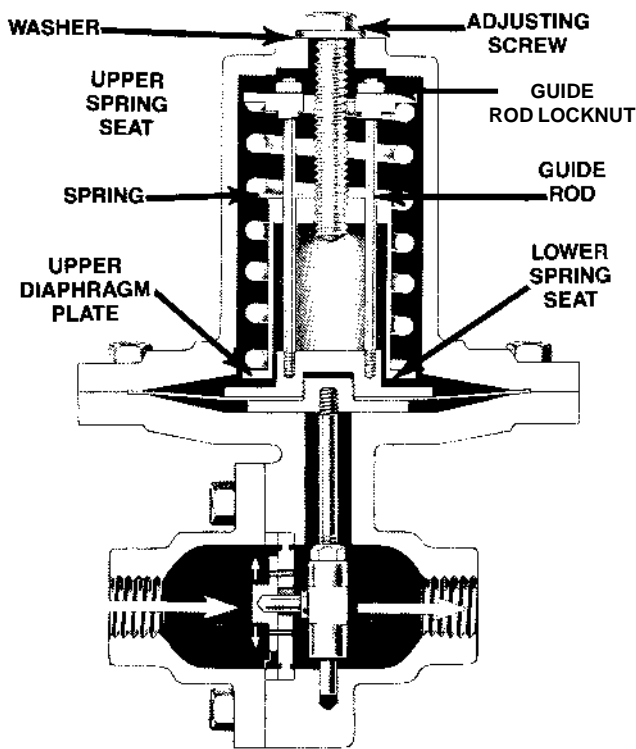

MARK 65*

*Drawing shows valve in open position, in static condition spring actually keeps valve stroked up and closed.

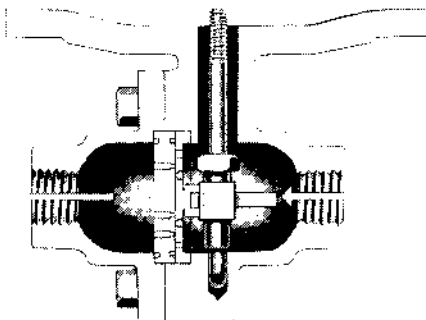

MARK 55**

**Drawing shows valve in closed position, in static condition spring actually keeps valve stroked up and open.

Installation

The installation instructions for the Vacuum Regulator are identical to the instructions for the Mark 50 and Mark 60

Operation - Mark 55 & 65

To change the controlled vacuum setting, rotate non-rising adjusting screw clockwise to increase the vacuum setting. To decrease controlled vacuum setting, rotate the adjusting screw counterclockwise.

Maintenance

Caution: Ensure that the valve is de-pressurized before loosening any fittings or joints. The following steps are recommended before performing any maintenance on the valve:

1. Follow maintenance procedure listed in the MK 60 I & M for the MK65 and procedures for the MK50 for the MK 55.
2. For a spring replacement or range change follow the 50-60 I & M for Spring housing removal. Guide locknuts should be removed from the guide rods. Upper spring seat should be removed from the guide rods. Insert the new spring. Replace upper spring guide rods and secure the guide locknuts. Follow the 50-60 I & M for spring housing replacement.

Note: Refer to the drawing for proper description and proper orientation of parts.

Please Note

Use only genuine Jordan Valve parts to keep your valve in good working order. So that we can supply the parts which were designed for your valve, we must know exactly which product you are using. **The only guarantee to getting the correct replacement parts is to provide your Jordan Valve Representative with the valve serial number. This number is located on the valve identification tag. If the serial number is not available, the parts needed for your valve might be able to be determined with the following information:**

1. Model Number
2. Valve Body Size
3. Seat Material and Cv rating.
4. Spring Range and Set Point
5. Trim Material
6. Part Name - Number and Quantity (See parts list chart)

NOTE: Without a valve serial number, any parts ordered incorrectly are subject to up to a minimum 25% restock charge when returned.